

ABSOLUTE OPTICAL ROTARY ENCODER ETHERNET/IP



Main Features

- Compact and heavy duty industrial model
- Interface: EtherNet/IP
- Housing: 58 mm \varnothing
- Full shaft: 6 or 10 mm \varnothing /
hollow shaft 15 mm \varnothing
- Resolution: max. 30 Bit = 1,073,741,824
steps over 16384 revolutions
- Code: Binary
- Endless operation functionality

Mechanical Structure

- Flange and housing, Aluminum and Brass
respectively
- Stainless steel shaft
- Precision ball bearings with sealing rings
- Code disc made of durable and unbreakable
plastic
- Robust electrical connection with M12-connector

Programmable Parameters

- Resolution
- Total resolution
- Preset value
- Direction of rotation (complement)
- Velocity
- IP-Address

Electrical Features

- Integrated switch
- Status indication with six LEDs
- Temperature insensitive
IR-Opto-receiver-ASIC
- Polarity inversion protection
- Over-voltage-peak protection

ABSOLUTE ROTARY ENCODER ETHERNET/IP

Technical Data

Electrical Data

Supply voltage	10 - 30 V DC (absolute limits)
Power consumption	max. 2.5 Watt
EMC	Emitted interference: EN 61000-6-4
	Noise immunity: EN 61326-1
Bus connection	EtherNet/IP
Transmission rate	100 Mbit/s
Transmission	Shielded CAT-5 cable, ISO/IEC 8802-3
Accuracy of division	$\pm \frac{1}{2}$ LSB (up to 12 Bit), ± 2 LSB (up to 16 Bit)
Step frequency LSB	max. 800kHz (valid code)
Cycle time	[10 ms
Electrical lifetime	$> 10^5$ h
Cycle of write parameters	5 Mio
Device addressing	Programmable by BOOTP or DHCP

Mechanical Data

Housing	Aluminum, optional stainless steel
Lifetime	Dependent on shaft version and shaft loading – refer to table
Max. shaft load	Axial 40 N, radial 110 N
Inertia of rotor	$\leq 30 \text{ gcm}^2$
Friction torque	$\leq 3 \text{ Ncm}$ ($\leq 5 \text{ Ncm}$ with shaft sealing)
RPM (continuous operation)	max. 12,000 RPM
Shock (EN 60068-2-27)	$\leq 30 \text{ g}$ (halfsine, 11 ms)
Permanent shock (EN 60068-2-29)	$\leq 10 \text{ g}$ (halfsine, 16 ms)
Vibration (EN 60068-2-6)	$\leq 10 \text{ g}$ (10 Hz ... 1,000 Hz)
Weight (standard version)	Singleturn: $\approx 500 \text{ g}$
	Multiturn: $\approx 700 \text{ g}$

Flange	Synchro (S)		Clamp (C)	Hollow shaft (B)
Shaft diameter	6 mm	10 mm	10 mm	15 mm
Shaft length	10 mm	20mm	20 mm	-
hollow shaft depth min. / max.	-	-	-	15 mm / 30 mm

ABSOLUTE ROTARY ENCODER ETHERNET/IP

Minimum (mechanical) lifetime

Flange	Lifetime in 10^8 revolutions with F_a / F_r		
	40 N / 60 N	40 N / 80 N	40 N / 110 N
C10 (Clamp flange 10 x 20)	247	104	40
S10 (Synchro flange 10 x 20)	262	110	42
S6 (Synchro flange 6 x 10) without shaft sealing	822	347	133

S6 (Synchro flange 6 x 10) with shaft sealing: max. 20 N axial, 80 N radial

Environmental Conditions

Operating temperature	- 40 .. + 85°C
Storage temperature	- 40 .. + 85 °C
Humidity	98 % (without liquid state)
Protection class (EN 60529)	Casing side: IP 67
	Shaft side: IP 64 (optional with shaft sealing: IP67)

ABSOLUTE ROTARY ENCODER ETHERNET/IP

Pinning

Connector Ethernet

4 pin female, D-coded

Pin Number	Signal
1	Tx +
2	Rx +
3	Tx -
4	Rx -

Connector power supply

4 pin male, A-coded

Pin Number	Signal
1	US (15 - 30 V DC)
2	N.C.
3	GND (0V)
4	N.C.

Sketch on encoder view



Diagnostic

LED	Color	Description for LED = on
Active1	Yellow	Incoming and outgoing traffic for port 1
Link1	Green	Link to another Ethernet component for port 1
Active2	Yellow	Incoming and outgoing traffic for port 2
Link2	Green	Link to another Ethernet component for port 2
Stat1	Green	Status 1, details in the user manual
Stat2	Red	Status 2, details in the user manual

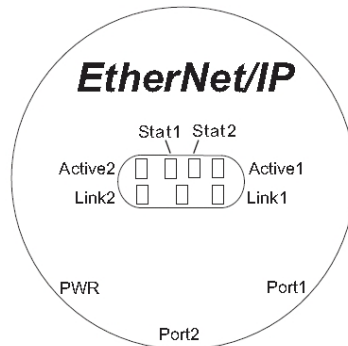

ABSOLUTE ROTARY ENCODER ETHERNET/IP

Programmable Parameters

The EtherNet/IP interface supports the Encoder Device with device type 22_{hex} functionality or the Generic Device type 0_{hex} according to the CIP specification. In addition to these functions the

EDS-file supports further features. Further more, the following encoder parameters can be programmed directly via the EtherNet/IP network without any extra device:

Parameter	Description
Counting Direction	This parameter counting direction defines whether the output code increases or decreases when the shaft rotates clockwise.
Resolution per Revolution	The parameter 'resolution per revolution' is used to program the desired number of steps per revolution. Each value between 1 and the physical resolution per revolution can be programmed.
Total Resolution	This parameter is used to program the desired number of measuring units over the total measuring range. This value may not exceed the total physical resolution of the absolute rotary encoder.
Preset Value	The preset value is the desired position value, which should be reached at a certain physical position of the axis. The position value is set to the desired process value by the parameter preset.
Velocity	The implemented software can additionally deliver the current velocity. It is possible to choose between four different units: steps per 10 ms, per 100 ms, per 1000 ms and revolutions per minute.

Details are available in the user manual. These can be downloaded free of charge from our homepage www.posital.eu.

ABSOLUTE ROTARY ENCODER ETHERNET/IP

Mechanical Drawings

Synchro Flange (S) available in 2 versions

Synchro flange	d / mm	l / mm
Version S06	6 _{f6}	10
Version S10	10 _{h8}	20

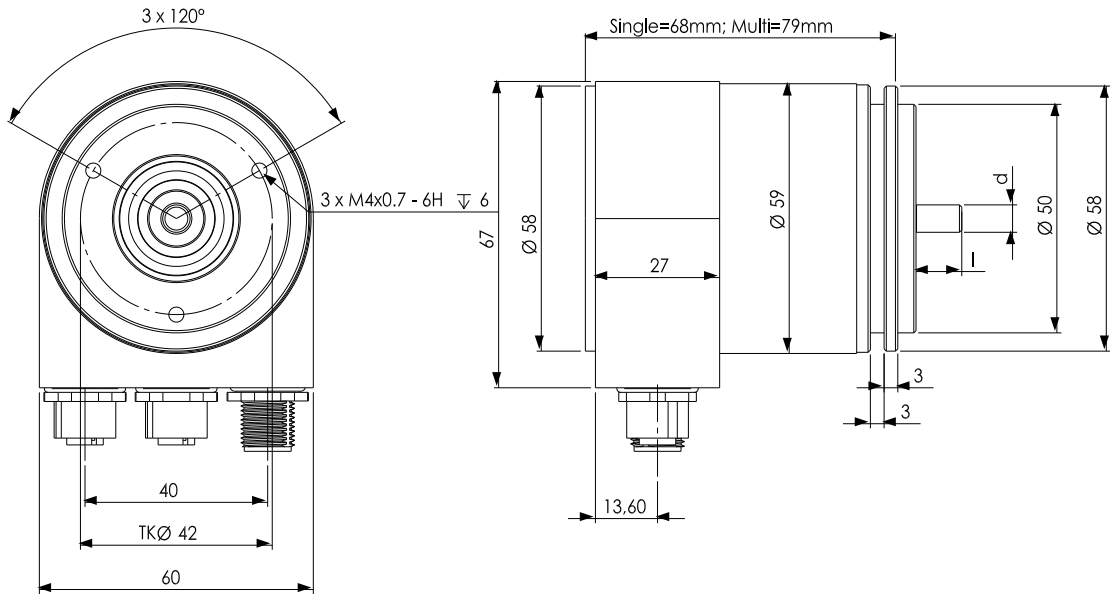

Clamp Flange (F)

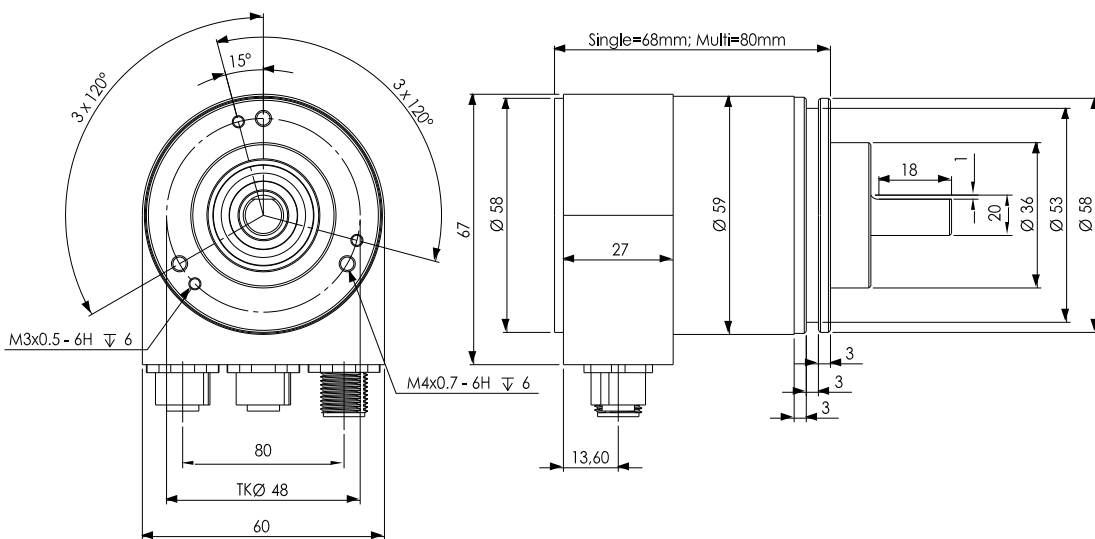

ABSOLUTE ROTARY ENCODER ETHERNET/IP

Hollow shaft (B)

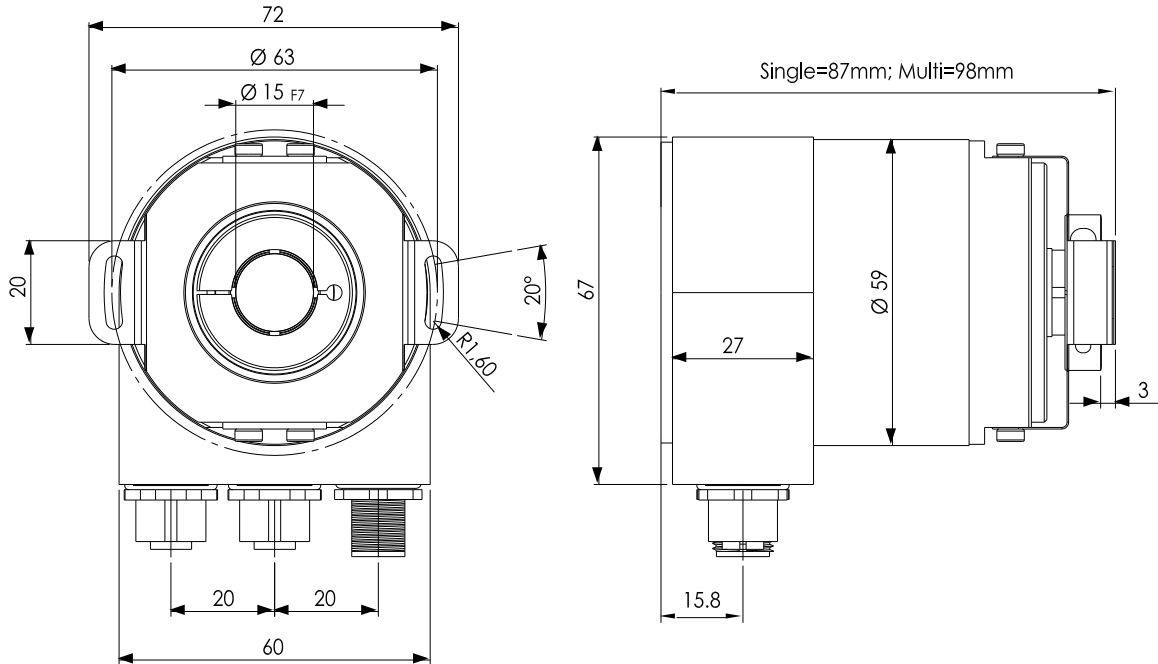

Mounting instructions

The clamp ring should only be tightened after the shaft of the driving element was inserted into the hollow shaft.

The diameter of the hollow shaft can be reduced to 12 mm, 10 mm or 8 mm by using an adapter (this reducing adapter can be pushed into the hollow shaft).

Maximum radial and axial misalignment of the drive shaft:

	axial	radial
static	± 0.3 mm	± 0.5 mm
dynamic	± 0.1 mm	± 0.2 mm

ABSOLUTE ROTARY ENCODER ETHERNET/IP

Models/Ordering Description

Description	Type	Key						
IXARC Optical Interface	OCD-	EE	00	B -	--	--	--	- PRM
Interface	EtherNet/IP	EE						
Version	With integrated switch		00					
Code	Binary			B				
Revolutions (Bits)	Singleturn						00	
	Multiturn (4,096 revolutions)						12	
	Multiturn (16,384 revolutions)						14	
Steps per revolution	8,192						13	
	65,536						16	
Flange / Shaft diameter	Clamp flange, full shaft:			Ø 10 mm			C10	
	Synchro flange, full shaft:			Ø 6 mm			S06	
				Ø 10 mm			S10	
	Blind hollow shaft, hollow shaft :			Ø 15 mm			B15	
Mechanical options	Without						0	
	Shaft sealing (IP67)						S	
	Customized						C	
Connection	M12 connector							PRM

Standard = bold, further models on request

ABSOLUTE ROTARY ENCODER ETHERNET/IP

Accessories and Documentation

Description		Type
Male cable connector	M12, 4 pin, D-Coded	PAM4
Female cable connector	M12, 5 pin	PAM5
Coupling *	Drilling: Ø 10 mm	GS 10
	Drilling: Ø 6 mm	GS 06
Clamp disc *	Set = 4 pcs.	SP 15
Clamp half-ring *	Set = 2 pcs.	SP H
Reducing adapter **	15 mm to 14 mm	RR14
	15 mm to 12 mm	RR12
	15 mm to 11 mm	RR11
	15 mm to 10 mm	RR10
	15 mm to 8 mm	RR8
User manual ***	Installation / configuration manual, English	UMD-EE
EDS file ***	Electronic Data Sheet	
BOOTP/DHCP- Configuration Tool ***	Details in the ZIP-file	

* Usable only for solid shaft

** Usable only for hollow shaft

*** These can be downloaded free of charge from our homepage www.posital.eu.

We do not assume responsibility for technical inaccuracies or omissions. Specifications are subject to change without notice.

ABSOLUTE ROTARY ENCODER
ETHERNET/IP